

# NOx Sensor

USER MANUAL



# Table of content

3	Principle of operation
4	User Manual
6	Troubleshoot
7	Warranty



## For direct replacement of OE sensors **NOx sensors**

The new NOx Sensor ensures accurate urea dosing and can replace the OE sensor directly.

### **An essential part of modern trucks**

A NOx (nitric oxide) sensor is typically a high-temperature device that measures the level of oxides in exhaust systems, which is strictly regulated by authorities in all parts of the world.

The measurement also helps to optimize engine operation, ensuring proper functioning of the exhaust after-treatment system.

### **Thoroughly tested**

All NOx sensor products match OE criteria and are calibrated and controlled at test facilities. Parts available for Cummins, DAF, Detroit, Freightliner, International, Iveco, Kenworth, MAN, Mercedes-Benz, Paccar, Peterbilt, Renault, Scania and Volvo. All products have a 2 year unlimited mileage warranty.

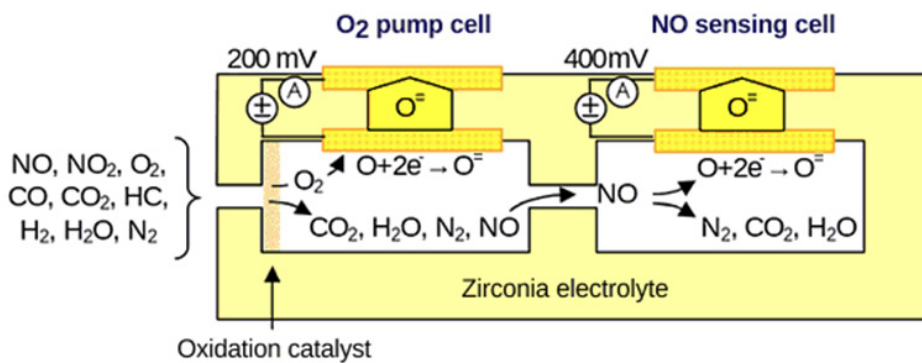
# Principle of operation

NOx sensor acts as oxygen sensor with extended functionality.

The sensing element is a ceramic chip (see Fig. 1) that consists of a heating circuit, small passage leading into two cavities, oxygen pumping circuit and NOx decomposition circuit.



**Figure 1.** NOx sensing element (chip)



**Figure 2.** NOx sensing element in longitudinal section view

Before operation, the ceramic chip is heated for approximately 1,5 minutes for it to become functional. As the exhaust gas enters the ceramic chip through the small passage (see Fig. 2), at the first cavity all the free oxygen molecules are pumped through the electrolyte and remaining gasses diffuse into the second cavity where NOx molecules are decomposed and the resulting oxygen measured as a small electric current. Additional circuit board (see Fig. 3) is used to convert the measured current to a signal which is compatible with the Engine Control Unit (ECU) communications protocol.



**Figure 3.** Sensor circuit board

# User Manual

## Choose the correct part number:

- Only use the NOx-sensor for the OE numbers and Continental references approved by Dinex;
- In the choice of replacement NOx sensor, it is advised to use Continental references;

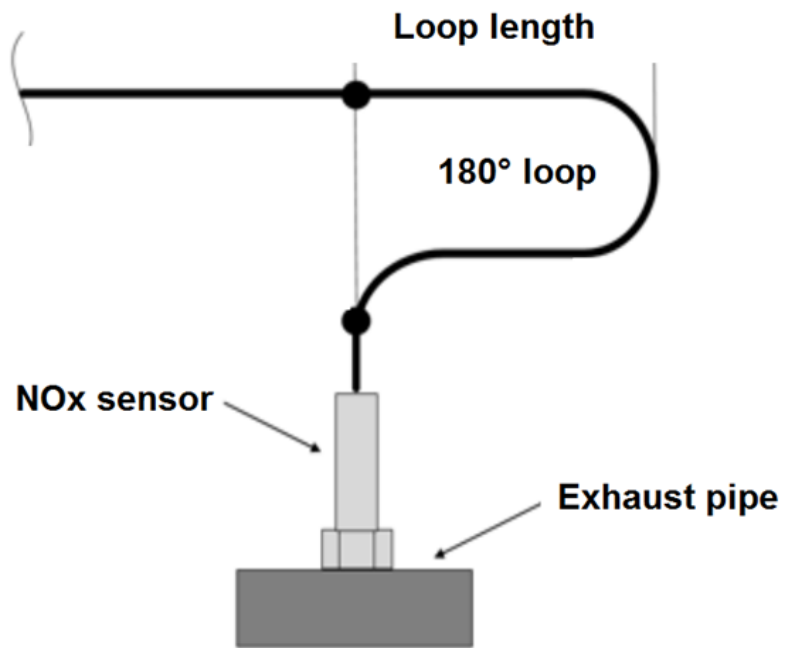


For references visit our web catalog, contact your local Dinex supplier or check out our NOx sensor list at [dinex.net/downloads/product-news](http://dinex.net/downloads/product-news)

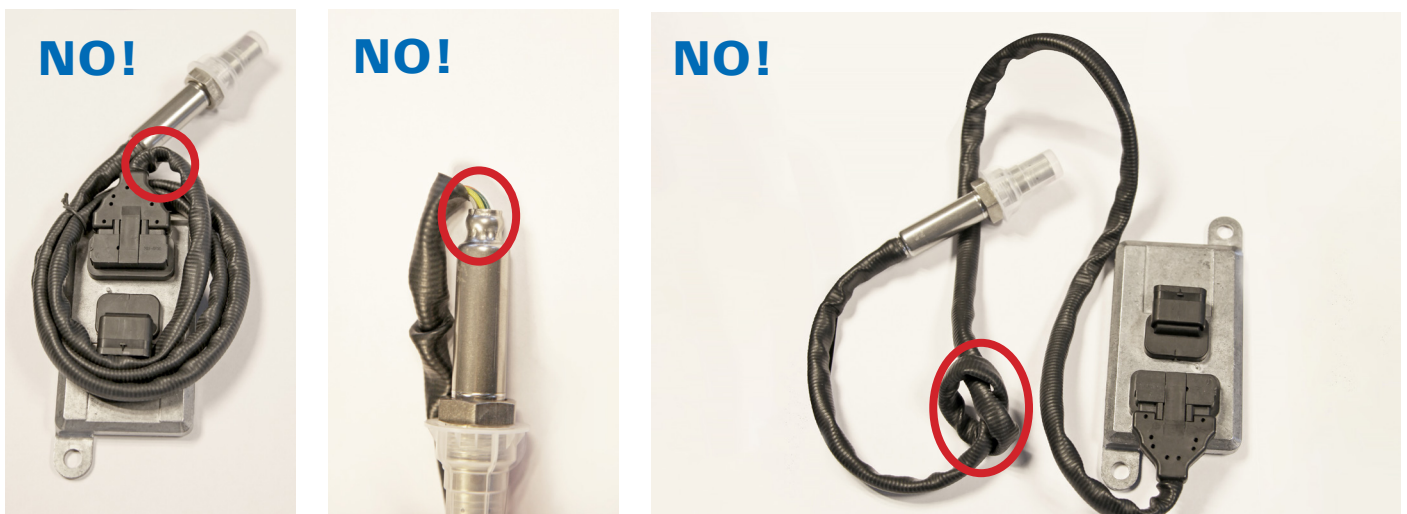
The supply voltage of Dinex NOx sensors is limited within 9 – 36 Volts and the signal voltage ranges from 2.5 to 3.6 Volts. It is strictly prohibited to alter the arrangement of connector wires.

During storage or installation, please make sure that the sensor wires are hanging tension-free. After proper installation the sensor wire should form a 180 degree loop to provide for safe play-distance (see Fig. 4).

It is likewise prohibited to wind or bend the wire (see Fig. 5).



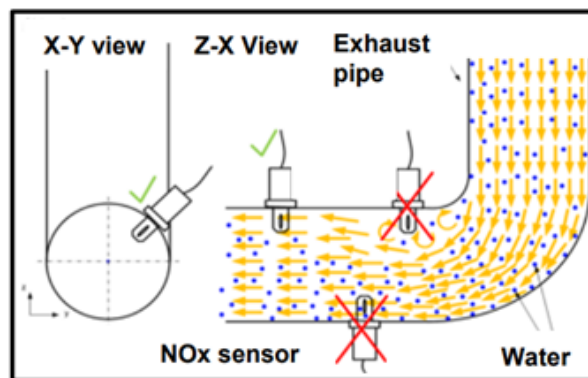
**Figure 4.** Suggested wire handling during installation.



**Figure 5.** Inappropriate wire handling.

When installing the NOx sensor in non-specific (new) designations, please consider sensor locations carefully. It should not be placed overly close to bends, as the turbulence will disturb proper operation.

The installation angle should be up-right, considerable distance away from any bends (see Fig. 6).



**Figure 6.** Sensor placement suggestion.

## Installation

- The sensor must be replaced and conditioned according to the vehicle manufacturer's specifications and service manual
- Clean and degrease the sensor port before the installation
- The sensor head must be tightened to a torque of  $50\text{Nm} \pm 10\text{Nm}$  in the sensor port
- The cable must be tension-free, cable and connectors must not be damaged or sharply bent
- During conditioning, error messages and old stored NOx values must be cleared; suitable diagnostic equipment might be required for this purpose

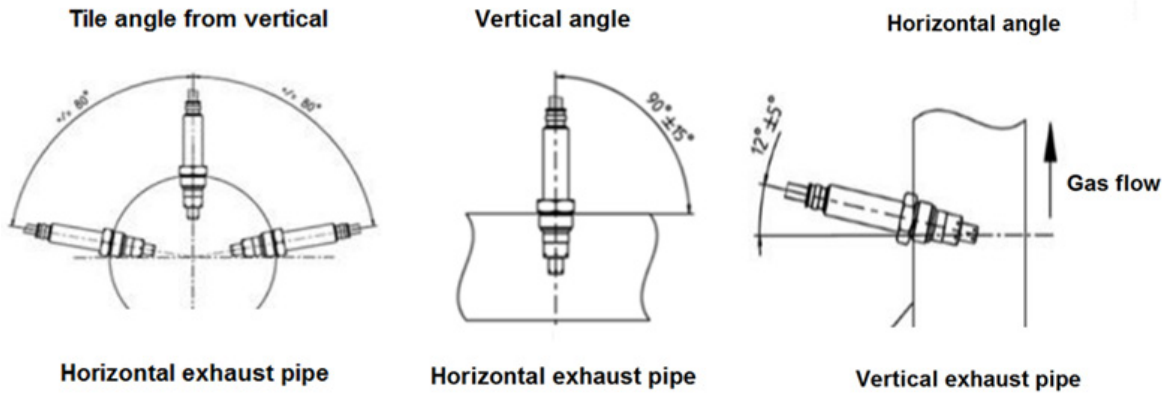


Watch our Dinex NOx sensor installation guide or visit our Technical support page at [dinex.net/downloads/technical-support](https://dinex.net/downloads/technical-support)

## Attention! Be cautious!

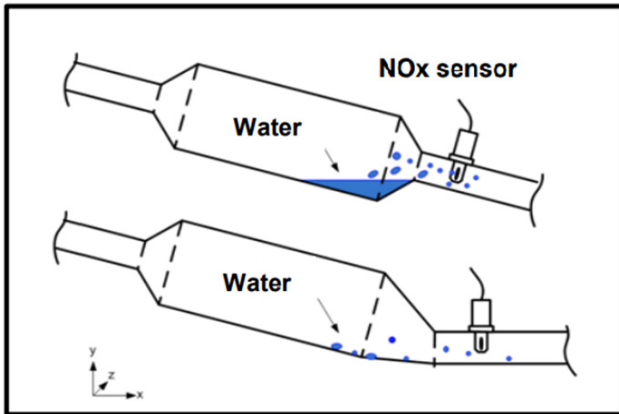
- The sensor must not be sprayed or treated with cleaners, oils, paints or compressed air
- The NOx-sensor is fragile, a ceramic chip in sensor head can break if subjected to strong vibrations; Don't drop the sensor, handle it with care
- Installation may only be carried out by trained specialist personnel



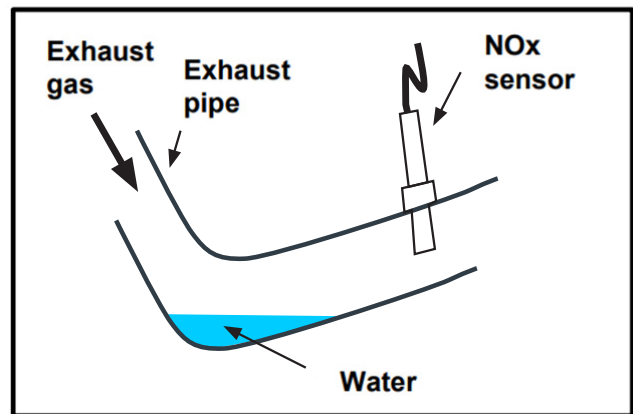


**Figure 7.** Sensor placement angles.

When choosing the location of a NO<sub>x</sub> sensor, please also consider the potential for pools of condensate water to form in the exhaust system. Some examples of this issue are illustrated in figures 8 and 9. The sensor location should be chosen such that during operation there is no risk for the condensate water to come in contact with the sensor head. Additional placement suggestions are given in figure 7.



**Figure 8.** Potential condensate pool in a silencer.



**Figure 9.** Potential condensate pool in a vertical bend.

When replacing a NO<sub>x</sub> sensor please pay attention to its' designation. The sensors that are located before the catalyst are regarded as "upstream", but those that are located after the catalyst are considered as "downstream sensors". The NO<sub>x</sub> concentration in both of these locations is very different so in some applications different sensors might be used for upstream and downstream locations. It is very important to avoid any mix-ups.

Please handle the product with care, do not use any spraying agents or chemicals to clean or paint them, do not attempt washing the sensor and its components with water or dismantling it. The use of such methods poses serious risk of failure (see Fig. 10).



**Figure 10.** Prohibited handling.

# Troubleshoot

Before replacing the old NOx sensor it is important to understand why it failed. Possible reasons for failures are listed below:

- Excessive soot/ash content in exhaust gas. The sensor head will be black (see figure 12).
- Contaminated exhaust gasses. Engine oil contamination is a common issue indicating worn out engine components.
- Lacking or excessive supply voltage due to short circuit, sudden voltage spikes or external power source.
- Direct contact with condensate during operation.
- Moist or damaged connector

It is important to fix any of the listed issues before installing a new NOx sensor otherwise the risk of repeated damage remains. If the freshly installed sensor is not recognized or does not function, please use a multimeter to see if the power supply at the sensor connector conforms with vehicles electrical system. Please also make sure that you follow any instructions regarding NOx sensor replacement issued by the manufacturer of your vehicle. If the sensor connects and is recognized but is showing signs of abnormal function, please make sure that the correct sensor is selected for its' location (upstream or downstream – refer to user manual section).

## Troubleshoot and resolve

- Compare new and old sensors; the OE number/Continental number must match the correct Dinex part, to ensure functionality
- Check if the sensor is installed in the correct position. Don't mix pre and post SCR sensor locations.
- Check cables and connectors for damages
- Check power supply to the sensor
- Before sensor conditioning, old NOx values must be deleted.
- If a newer sensor model is used, based on the vehicle manufacturer's replacement recommendation, the vehicle must be updated to the latest software version
- The sensor must be conditioned exactly according to the vehicle manufacturer 's specifications; if conditioning is skipped, various error messages may occur, because the vehicle cannot correctly or completely process the sensor's data
- If the old NOx sensor head was blocked by carbon/dirt or if there is a high level of carbon buildup or moisture in the exhaust, such bad conditions can quickly damage the new Nox sensor. The engine and exhaust system should be checked for failures
- The engine must have reached its operating temperature before the function check of the sensor is carried out
- In case of overly low or high NOx reading, the exhaust system should be checked for AdBlue quality or other sensor and AdBlue system component failures

# Warranty

Please make sure that all the issues from troubleshoot section have been repaired before installing Dinex product. If evidence of any of the issues listed under troubleshoot section will be detected during warranty investigation, the claim will be rejected. Likewise, the sensor body and wiring must not bear visible signs of damage in order for the warranty to be valid. If the sensor thread or nut has sustained damage, it is evidence of excessive force that can potentially lead to failure (see Figure 11).



**Figure 11.** Damaged sensor thread and nut.

If there are considerable stains of soot/ash on the sensor head (see Figure 12) it is evidence of a damaged DPF or poorly calibrated engine operation. The sensor chip in this case is easily damaged therefore warranty becomes void.



**Figure 12.** Evidence of excessive soot/ash.

Damaged wire protector is evidence of poor handling (see Figure 13) that can result in damaged wiring. In order for the warranty to be valid there must be no signs of wire damage.



**Figure 13.** Damaged wire protector.

The area where wiring connects to the sensor head is most critical and prone to connection loss if treated poorly (see Figure 14). In case of damage, the warranty will not be valid.



**Figure 14.** Evidence of damaged wiring.

Do not attempt to wash or submerge the sensor. Do not use any spraying agents. Store in dry environment only. If evidence of water will be found in the sensor head, or any chemical traces will be found on the product, the warranty will be void.

- Headquarter
- Tech. Center
- Factory
- Warehouse & Distribution

- Dinex A/S, DK
- Dinex Latvia SIA, LV
- Dinex Emission Inc., US
- Dinex Egzoz ve Emisyon Tekn.sa, TR
- Dinex Exhausts Ltd., GB

- Dinex Polska Sp. Z.o.o., PL
- Dinex SAS, FR
- Dinex Italia S.R.L., IT
- Dinex Ibérica Sistemas de Esca, ES
- Dinex Balkan D.O.O., RS
- Dinex Deutschland GmbH (Kalbach), DE



Check out our installation guide video by scanning the QR code with your smartphone



going the extra mile